

Marsh-McBirney FLO-DAR™ with Flo-Station™ Radar Velocity/Area Flow Meter



The Flo-Dar Flow Meter with Flo-Station provides an ideal solution for non-contact, maintenance-free permanent sewer flow monitoring.

Features and Benefits

The Flo-Dar Radar Velocity/Area Flow Meter provides a revolutionary approach to open channel flow monitoring. Flo-Dar combines advanced Digital Doppler Radar velocity sensing technology with ultrasonic pulse echo level sensing to remotely measure open channel flow. Combined with Flo-Station, users have a permanent solution for flow measurement needs.

Accurate Flow Measurement

Flo-Dar provides the user with highly accurate flow measurements under a wide range of flows and site conditions. By measuring the velocity of the fluid from above, Flo-Dar eliminates accuracy problems inherent with submerged sensors including sensor disturbances, high solids content and distribution of reflectors.

Non-Contact Sensor Eliminates Lost Data

No lost data with non-contact, above the flow sensor that is unaffected by fouling due to debris and grease.

Easy Installation and Maintenance

As the sensor is mounted above the flow, personnel have little or no contact with the flow during installation. Future sensor removal can be done without the need for confined space entry.

Perfect Solution for Difficult Flow Conditions

Operates in the most difficult conditions including flows with high solids content, high temperature, shallow and caustic flows, large man-made channels, and high velocities up to 20 ft/s.

Optional Surge Velocity Sensor

During surge events Flo-Dar's optional electromagnetic sensor will continue to provide uninterrupted and accurate flow monitoring through dry and wet weather flows without the need for routine sensor cleaning or maintenance.

Multiple Uses

Receive accurate flow measurement for billing purposes, EPA permitting requirements, inflow/infiltration studies, combined sewer overflow monitoring, process control, sampling pacing, modeling/sewer system evaluations, and wastewater treatment plant balancing.

Intrinsically Safe Models Available

Hazardous locations can be accommodated with the I.S. model.

Applications

Municipal

- Sanitary Sewer Evaluation Studies
- Collection Systems
- Capacity Studies
- Combined Sewer Overflows
- Inflow and Infiltration (I&I) Studies
- Billing / Custody Transfer
- Plant Influent and Effluent

Industrial

- Process Waste
- Plant Influent
- Plant Effluent
- Non-contact Cooling Water
- Stormwater Monitoring and Compliance

DW = drinking water WW = wastewater municipal PW = pure water / power
IW = industrial water E = environmental C = collections FB = food and beverage



Be Right™

WW

IW

C

Specifications*

FLO-DAR SENSOR (Without SVS)

Enclosure

IP 68 Waterproof rating, Polystyrene

Dimensions

160.5 W x 432.2 L x 297 D mm (6.32 x 16.66 x 11.7 in.), with SVS, D = 387 mm (15.2 in.)

Weight

4.8 kg (10.5 lbs.)

Operating Temperature

-10 to 50°C (14 to 122°F)

Storage Temperature

-40 to 60°C (-40 to 140°F)

Power Requirements

Supplied by Flo-Station

Interconnecting Cable

-Disconnectable at both sensor and logger

Polyurethane, 0.400 (±0.015) in. diameter; IP68
Standard length 9M (30 ft), maximum 305 m (1000 ft)

Certification

FCC Rules Part 15, Subpart C; Industry Canada RS-S210
(No user license required)

SURCHARGE DEPTH MEASUREMENT

Auto zero function maintains zero error below 0.5 cm (0.2 in.)

Method

Piezo-resistive pressure transducer with stainless steel diaphragm

Range

3.5 m (138 in.), overpressure rating 2.5 x full scale

VELOCITY MEASUREMENT

Method

Radar

Range

0.23 to 6.10 m/s (0.75 to 20 ft/s)

Frequency Range

24.075 to 24.175 G-Hz, 15.2mW (max.)

Accuracy

±0.5%; ±0.03 m/s (±0.1 ft/s)

DEPTH MEASUREMENT

Method

Ultrasonic

Standard Operating Range from Flo-Dar Housing to Liquid

0 to 152.4 cm (0 to 60 in.)

Optional Extended Operating Range from Transducer Face to Liquid

0 to 6.1 m (0 to 20 ft.) with 43.18 cm (17 in.) dead band, temperature compensated.

Accuracy

±1%; ±0.25 cm (±0.1 in.)

FLOW MEASUREMENT

Method

Based on Continuity Equation

Accuracy

±5% of reading typical where flow is in a channel with uniform flow conditions and is not surcharged, ±1% full scale max.

SURCHARGE CONDITIONS DEPTH/VELOCITY

DEPTH (Std with Flo-Dar Sensor)

Surcharge depth supplied by Flo-Dar sensor.

VELOCITY (Optional Surcharge Velocity Sensor)

Method

Electromagnetic

Range

±4.8 m/s (±16 ft/s)

Accuracy

±0.15 ft/s or 4% of reading, whichever is greater.

Zero Stability

> ±0.05 ft/s

FLO-STATION PERMANENT AC/DC POWERED ELECTRONICS

Data Storage

64K (16K cycles of velocity/depth data)

Local Terminal

RS232C at 19.2K baud

Optional Display

Dimensions: 1 in. x 3 in. Four lines of text display, FLOW, LEVEL, VELOCITY, FLOW TOTAL or any combination of any four channels containing data. Screens may be programmed to alternate values displayed.

Time-Based Accuracy

1 second per day

Outputs

Four 4-20 mA outputs: system-isolated, up to 600 ohm load. Outputs are flow, level, velocity or surcharge level.

Contact Closure

Dry contact closure with adjustable duration selectable for flow-proportional or alarm based on: FLOW, LEVEL, VELOCITY, SURCHARGE LEVEL, TEMPERATURE, BATTERY VOLTAGE, EACH SAMPLE, BAD SAMPLE OR ANALOG INPUT.
Rating: 1A @ 30 Vdc (resistive) 0.5A @ 125 Vac (resistive)

Power Requirements

AC: 85-264 Vac, 47-63 Hz, 32 watts

DC: 12 Vdc for Flo-Station without display or Flo-Station with display (backlight off) 180 mA (2.1 watts) with (1) 4-20 mA utilized.

Housing

Material: ABS plastic, NEMA 4
Dimensions: 257.8 W x 236.7 H x 95.3 D mm (10.15 W x 9.32 H x 3.75 D in.)
Weight: 2.3 kg (5 lbs)

Operating Temperature

Operating Range: -10 to 50°C (14 to 122°F)
-20 to 50°C (-4 to 122°F) without display

Continued on next page.

Specifications *continued*

Storage Temperature

Without Display: -40 to 60°C (-40 to 140°F)
With Display: -20 to 60°C (4 to 140°F)

Set-up/Data Retrieval

Flo-Ware for Windows software is the user on-site set-up, data management, and report generation software. It is compatible with desktop/portable computers utilizing

Windows 95/98/2000/Me/NT/XP. Flo-Ware FX for PocketPC has all the same functionality as Flo-Ware for Windows with the exception of report generation.



Both Flo-Dar sensor and Flo-Station meet CE requirements.

**Specifications subject to change without notice.*

Engineering Specifications

FLO-DAR SENSOR WITH FLO-STATION

- The flow meter shall be capable of measuring level, average velocity and surcharge depth.
- The method of velocity measurement shall be Doppler radar.
- The sensor shall combine advanced Doppler Radar velocity sensing technology with ultrasonic pulse echo depth sensing to remotely measure open channel flow.
- Flow shall be calculated based on the Continuity Equation ($Q=V \times A$), where Q =Flow, V =Average Velocity and A =Area.
- The range of velocity measurement shall be 0.23 to 6.10 m/s (0.75 to 20 ft/s).
- The method of depth measurement shall be ultrasonic.
- The standard operating range for depth measurement shall be 0 to 152.4 cm (0 to 60 in.) with an optional operating range of 0 to 6.1 m (0 to 20 ft.) with 43.18 cm (17 in.) deadband, temperature compensated.
- The flow meter shall have a surcharge condition velocity sensor option.
- Exterior dimensions of the sensor shall not exceed 160.5 W x 432.2 L x 297 D mm (6.32 W x 16.66 L x 11.7 D in.) or 160.5 W x 432.2 L x 387 D mm (6.32 W x 16.66 L x 15.2 D in.) with Surcharge Velocity option.
- The flow meter shall be the Marsh-McBirney Flo-Dar with Flo-Station Open Channel Flow Meter.

Dimensions

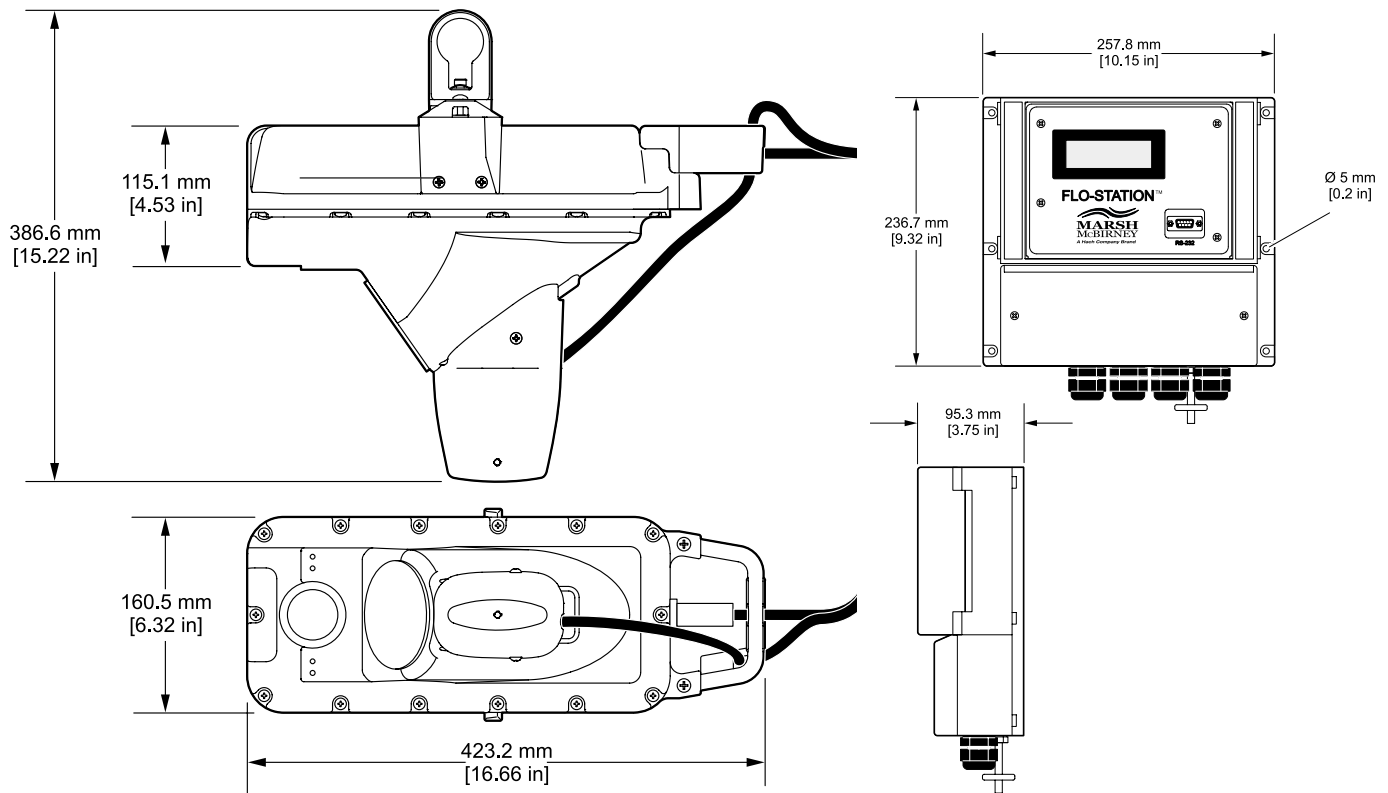

FLO-DAR Sensor

Flo-Station

Ordering Information

		Cable Length	Surcharge Option	Extended Range	
Flo-Dar Sensors	Model 4000-	—	—	—	
30 ft.		6			
60 ft.		7			
100 ft.		8			
As needed (Max 1000 feet)		9			
No			0		
Yes			3		
Standard				0	
Extended Range Option				1	
Extended Range Option w/Remote Depth Sensor				2	
		Power	Display	Flo-Ware Software	Surcharge Option
Flo-Dar Electronics (Flo-Station)	Model 1104-	—	—	—	
12 VDC		1	No		
120/240 AC		2	No		
Flo-Dar Electronics (Flo-Station)	Model 1204				
12 VDC		1	Yes		
120/240 AC		2	Yes		
Flo-Ware Model 1204				0	
Flo-Ware Model 1104				1	
No					0
Yes					1

Mounting Hardware

800016701	Permanent Mount includes sensor frame and all mounting hardware Portable Sensor Mount includes jack bar assembly, frame, and all hardware
800016401	34-54 inch manhole diameters
800016402	52-70 inch manhole diameters
800016403	70-88 inch manhole diameters
800016404	89-107 inch manhole diameters
800012402	Laser Alignment Tool

Accessories & Spares

55032	Desiccant Replacement Cartridge (must be used when Flo-Station is in a moist environment)
151000201	APR port protector (spare)
Odd Shape CHANN	Odd Shaped Table - Configures software for user's specified conduit
245000501	Sensor Retrieval Pole - Used to place and retrieve sensor from mounting bracket. Pole extends to 7.3 m (21 ft.)
510012701	Sensor Retrieval Hook - Used with Sensor Retrieval Pole
570011401	Grounding Strap (required with Retrieval Pole and Hook when used with IS units)
570007301	Flo-Station to Laptop Interface Cable - Spare
170007101	Stainless Steel ID Tag

Lit. No. 2616

J9 Printed in U.S.A.

©Hach Company, 2009. All rights reserved.

In the interest of improving and updating its equipment, Hach Company reserves the right to alter specifications to equipment at any time.

At Hach, it's about learning from our customers and providing the right answers. It's more than ensuring the quality of water—it's about ensuring the quality of life. When it comes to the things that touch our lives...

Keep it pure.

Make it simple.

Be right.

For current price information, technical support, and ordering assistance, contact the Hach office or distributor serving your area.

In the United States and all other countries except Europe, contact:

HACH COMPANY
4539 Metropolitan Court
Frederick, MD 21704-9452, U.S.A.
Telephone: 800-368-2723
Fax: 301-874-8459
E-mail: hachflowsales@hach.com
www.hachflow.com

In Europe contact:

Flow-Tronic
Rue J.H. Cool 19a
B-4840 Welkenraedt Belgium
Telephone: +32-87-899799
Fax: +32-87-899790
E-mail: site@flow-tronic.com
www.flow-tronic.com



Be Right™